

Opera Twin - Lock kit - 22 mm forend



Description

Mortice lock with magnetic movement and latch in plastic material to be coupled with a half cylinder or a standard cylinder from the AGB catalogue, which is not included in the kit. The bolt is automatic and made of sintered steel: when the magnetic latch comes out, the locking system acts accordingly. On the external sash, you have to use a fixed knob and the cylinder opening with the latch and bolt recall inside. Antipanic function on the internal side of the handle: turning down the handle, in every situation the bolt and latch will be released. The frame striker is adjustable at $\pm 1,5$ mm to guarantee optimal door closing. Axis 85 mm, 22 mm forend with round ends, backset 70 and through hub.

- Accessories included in the kit:**
- non-handed adjustable counterplate;
 - adjustable magnetic cover-tray;
 - cover tray for bolt hole;
 - fastening screws.

Use
 Suitable for use of fire resistant doors in wood, particularly hotel doors.
 Suitable for use on flush doors or doors with rebate.

Installation
 Fasten the lock with the provided plate and screws.
The drilling diagram is available in the online assembly instructions.

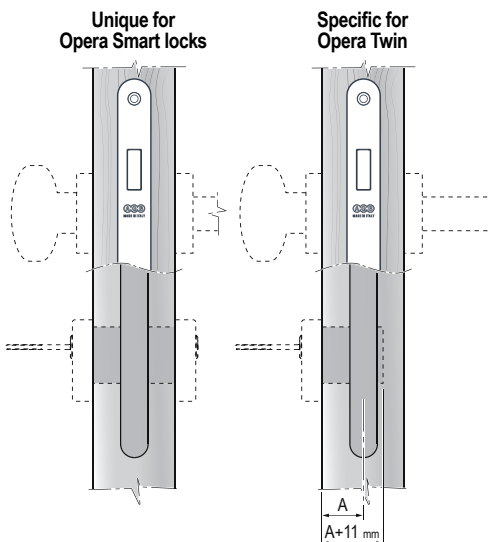
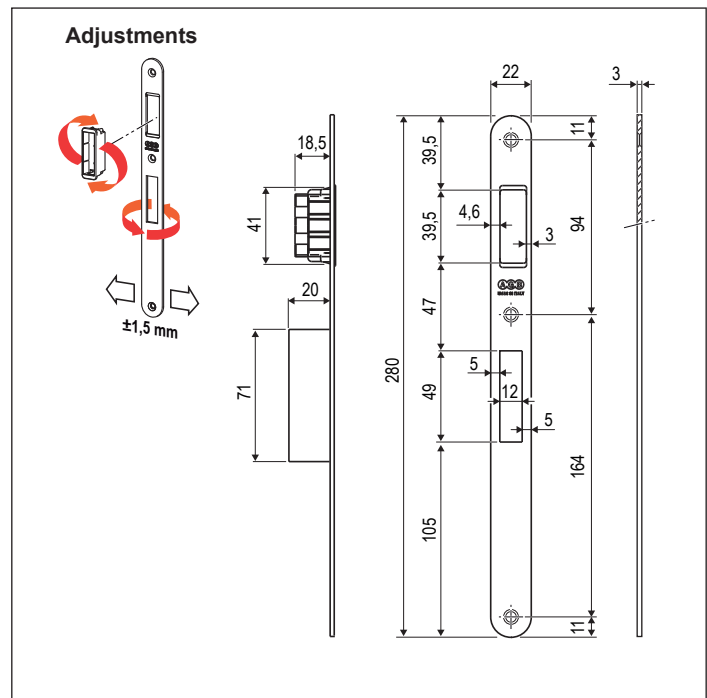
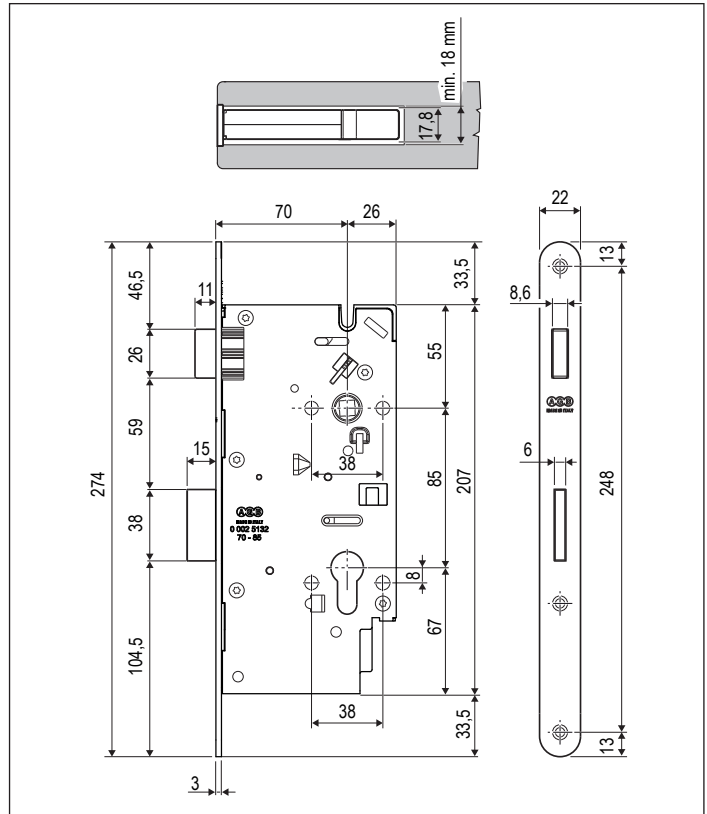

Opera Twin - Lock kit - 22 mm forend

FORMULA FOR CALCULATION OF XX HALF CYLINDER MEASUREMENT

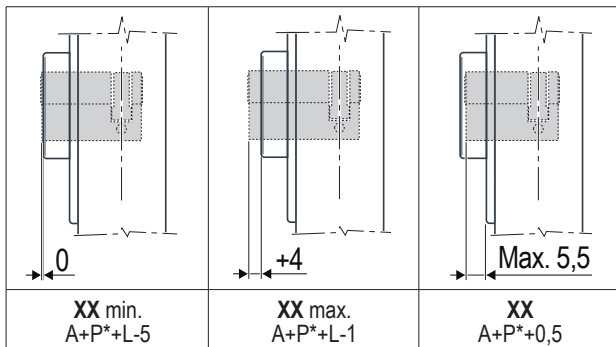

Note. To order the half cylinder, please check AGB Price List.
* If present.

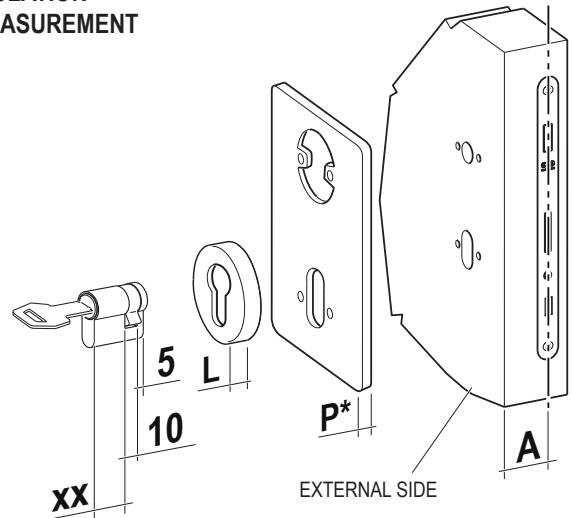

APPLICATION FIELDS

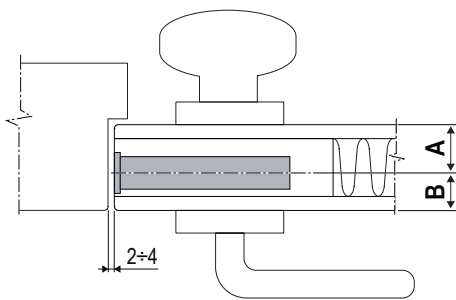

	min.	max.
A	16 mm	55 mm
B	16 mm	55 mm

A+B = 100 mm max.

Order specifications

Material	SALES CODE		
	Ref.	Backset	Finish
STEEL	B60039	70	XX

Note. Refer to the price list in force to check the availability of the finishes.